

PRORIL

50 Hz

Designed for light weight, excellent performance, low energy consumption, and easy maintenance, PRORIL submersible handy pumps serve a wide range of pumping applications on utility, construction, industrial, and municipal job sites.

Handy and Residue Pump

SAVVY JUMBO 300

Handy Pump



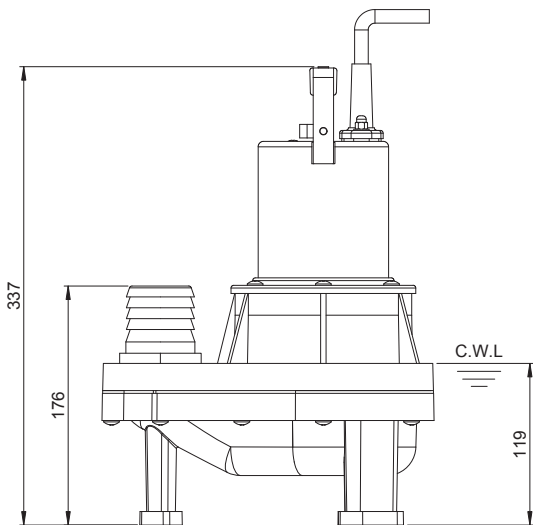
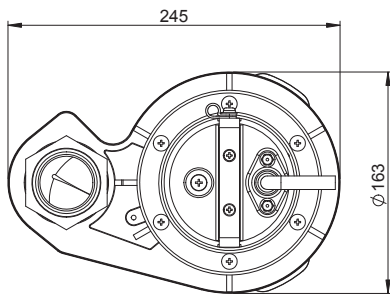

Weight : 4.2kg / 9.3 lbs

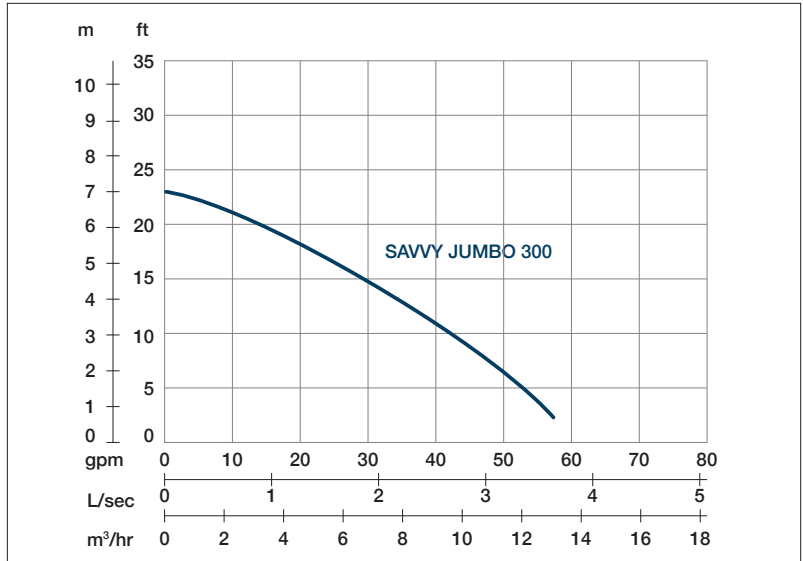

Shaft Speed : 2850 rpm Solid Passage : 35 mm Outlet : 50mm, 2in

OUTPUT	HEAD	FLOW
0.25 kW	Rated : 4m, 13ft	Rated : 2.2 l/s, 34 gpm
0.33 HP	Max : 7m, 23ft	Max : 3.7 l/s, 58 gpm

Pump Type	Electric Submersible Pumps	
	1-Phase	
Motor	Type	Induction Motor
	Poles	2 Pole
	Insulation	Class F
	Protector	Miniature Thermal Protector
	Starter	Capacitor-Run
Lubricant	Food Grade (ISO VG115)	
Impeller Type	Vortex	
Shaft Seal	Single Mechanical Seal	
	Ceramic / Carbon	
Bearings	C3 Shielded ball bearings	
Cable	H07RNF	
	Length: 10m (33ft) or longer upon request.	
Materials	Pump Casing	Plastic
	Impeller	Techno-polymer
	Motor Frame	Stainless Steel
	Motor Shaft	Stainless Steel
Max. Liquid Temperature	104°F (40°C)	
Max. Submersion Depth	66ft (20m)	
pH Range	pH 5 - pH 8	