

PRORIL

50 Hz

GOVOX Series, these vortex pumps are equipped with an agitator, which forcibly agitate the fluid for easy and efficient transmission of sludge, sand, mud and debris.

Sewage Pump

GOVOX-S 337

Vortex and agitator Pump



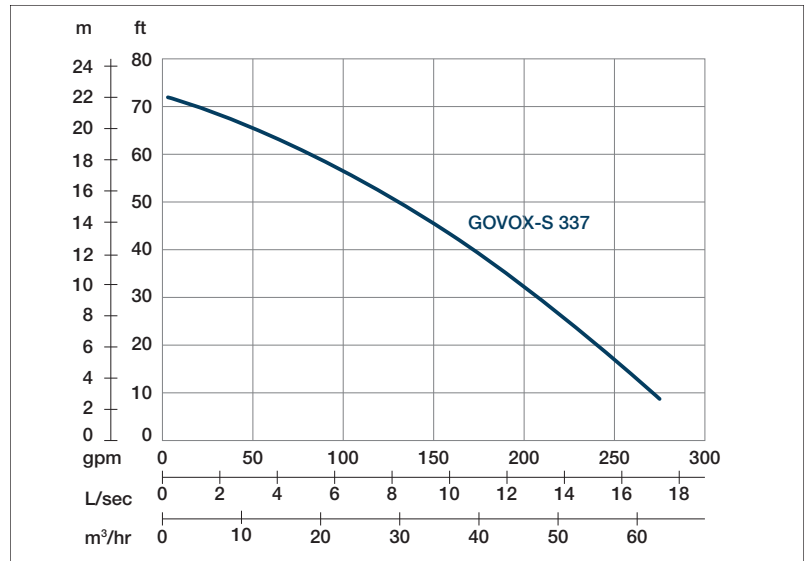

Shaft Speed : 2850 rpm Solid Passage : 13 mm Outlet : 80mm, 3in

OUTPUT	HEAD	FLOW
3.7 kW	Rated : 15m, 49ft	Rated : 8.3 l/s, 132 gpm
5 HP	Max : 22m, 72ft	Max : 17.5 l/s, 277 gpm

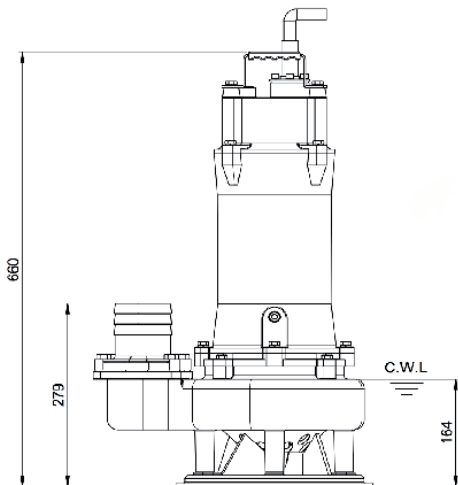
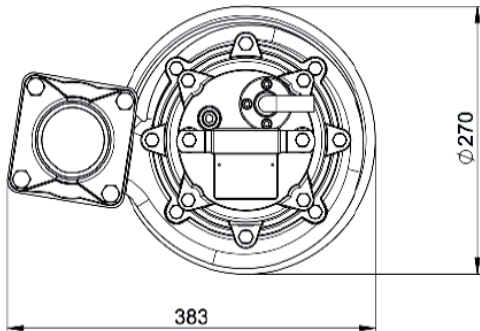

Weight : 57kg / 117lbs

Pump Type		Electric Submersible Pumps
		3-Phase
Motor	Type	Induction Motor
	Poles	2 Pole
	Insulation	Class F
	Protector	Circle Thermal Protector
	Starter Method	D.O.L.
Lubricant		Food Grade (ISO VG32)
Impeller Type		Vortex
Shaft Seal		Double Mechanical Seal Silicon Carbide VS Ceramic / Carbon
Bearings		C3 Shielded ball bearings
Cable		H07RNF Length: 10m (33ft) or longer upon request.
Materials	Pump Casing	Gray Iron
	Impeller	Gray Iron
	Motor Frame	Gray Iron
	Motor Shaft	Stainless Steel
	Agitator	Ductile iron
Max. Liquid Temperature		40°C (104°F)
Max. Submersion Depth		20m (66ft)
pH Range		pH 5 - pH 8