

4" 3-WIRE HIGH THRUST MOTOR

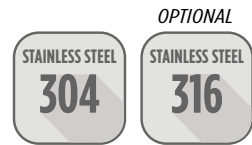

FEATURES & BENEFITS

- NEMA mounting design
- Stainless steel splined shaft
- StatorShield™ - Franklin encapsulation system
- Factory filled with Franklin's FES93 motor fill solution
- Max. storage temperature -15°C - + 50°C
- Liquid lubricated radial bearings and High capacity Kingsbury type thrust bearing for 100 % maintenance free operation
- Field replaceable lead using Franklin's exclusive Water Bloc technology
- optional Franklin Electric 3-wire control boxes for maximum system performance, protection and warranty
- Pressure-equalizing diaphragm
- High efficiency electrical design for low operation costs
- Drinking water approvals
- Suitable for use in water with increased salinity (Brackish water version optional)



Pollution Recovery version:

- Fluorelastomere (Viton®) rubber parts
- Special Polyuretane (PUR) lead assemblies
- 304SS (316SS Stator) graded stainless steel as standard

SPECIFICATION

- Rating: 2,2 - 3,7 kW, 1-
- Voltage: 1- - 220-230 V / 50 Hz, 230 V / 60 Hz
- Thrust load: 6,5 kN
- Nominal ambient temperature: 30 °C with 0.08 m/s cooling flow
- Voltage tolerance: -10 % / +6 % (50 Hz), ±10 % (60 Hz)
- Protection IP68 and insulation class B
- Frequency of starts: 20 starts/ hour (with min. 3 minutes resting time)
- motors with factory installed leads 2,5 m (optional)
- Installation orientation: Vertical / horizontal (shaft end heightened)
- Rotation counter clock wise facing shaft end (Rotation CW upon request)

OPTIONS

- Built in lightning arrestors
- Various cable lengths
- Motors with factory-installed lead in single packing
- Motor complete in 316SS with SiC seal
- Special voltages



ISO 9001

All motors are manufactured in ISO 9001 certified plants and 100% tested



Hydrodynamic liquid lubricated radial bearings

100 % maintenance free operation

StatorSHIELD™ - Franklin encapsulation system

Franklin Electric encapsulated motors are equipped with hermetically-sealed windings. The Anti track stator resin mechanically supports the winding and provides fast heat dissipation.

Kingsbury type thrust bearing

High capacity 4 kN Kingsbury type thrust bearing for 100 % maintenance free operation

Pressure-equalizing diaphragm



4" SUPER STAINLESS HIGH THRUST MOTOR - 3-WIRE DESIGN

MOTOR MODEL NUMBERS 50 HZ - 3-WIRE DESIGN

P _N [kW]	U _N [V]	Digit 1 - 6	Digit 7 - 10							
			304SS Standard		304SS Pollution Recovery		316SS Standard		316SS Pollution Recovery	
			Motors in single pack, with Lead)*	Motors in 40 motors packing unit	Motors in single pack, with Lead)*	Motors in 40 motors packing unit	Motors in single pack, with Lead)*	Motors in 40 motors packing unit	Motors in single pack, with Lead)*	Motors in 40 motors packing unit
2,2	220-230	224 752	3421L	3421	3422L	3422	3521L	3521L	3522L	3522
3,7	220-230	224 753	3421L	3421	3422L	3422	3521L	3521L	3522L	3522

* lead lengths motors: „L“ with 2.50 m pre-mounted cable

MOTOR MODEL NUMBERS 60 HZ - 3-WIRE DESIGN

P _N [kW]	P _{max.} [kW]	U _N [V]	Digit 1-6	Digit 7-10			
				304		316 SS	
				Motors in 40 motors packing unit	Motors in single pack, with Lead)*	Motors in 40 motors packing unit	Motors in single pack, with Lead)*
2,2	2,5	230	224 ---	3421	3421L	3521	3521L
3,7	4,2	230	224 703	3421	3421L	3521	3521L

* lead lengths motors: „L“ with 2.50 m pre-mounted cable

MOTOR PERFORMANCE DATA 50 HZ - 3-WIRE DESIGN

P _N [kW]	Thrust F [N]	U _N [V]	n _N [min ⁻¹]	I _N [A]	I _A [A]	η (Eff.) [%] at % load			cos φ (Pf.) at % load			T _N [Nm]	T _A [Nm]
						50	75	100	50	75	100		
						2,2	6500	220	2875	15,2	71,2		
230	2885	15,3	74,5	63	70			73	0,69	0,80	0,88	7,3	15,0
3,7	6500	220	2880	22,5	97	72	77	78	0,98	0,99	0,99	12,3	16,1
		230	2895	21,4	101	70	76	77	0,97	0,98	0,99	12,2	17,6

MOTOR PERFORMANCE DATA 60 HZ - 3-WIRE DESIGN

P _N [kW]	P _{max} [kW]	Thrust F [N]	U _N [V]	n _N [min ⁻¹]	I _N [A]	I _A [A]	η (Eff.) [%] at % load			cos φ (Pf.) at % load			T _N [Nm]	T _A [Nm]
							50	75	100	50	75	100		
							2,2	2,5	6500	230	3440	15,1		
3,7	4,2	6500	230	3450	24,5	102	70	76	77	0,98	0,99	0,99	11,7	16,1

WINDING RESISTANCE DATA 50 HZ 220-230V - 3-WIRE DESIGN

P _N [kW]	U _N [V]	Stator Ref.	Main phase [Ohm]	Start sphase[Ohm]
2.2	220 / 230	326 813 912	1,3 - 1,6	3,8 - 4,6
3,7	220 / 230	326 813 912	1,0 - 1,3	2,5 - 3,1

WINDING RESISTANCE DATA 60 HZ 230V - 3-WIRE DESIGN

P _N [kW]	P _{max} [kW]	U _N [V]	Stator-Ref. #	Main phase [Ohm]	Start sphase[Ohm]
2,20	2,5	230	326 897	1,3 - 1,6	3,5 - 4,3
3,7	4,2	230	326 898	0,9 - 1,1	1,7 - 2,1

MOTORDESIGN AND DIMENSION

MOTORDESIGN 304SS 6500N 2,2 - 3,7 KW

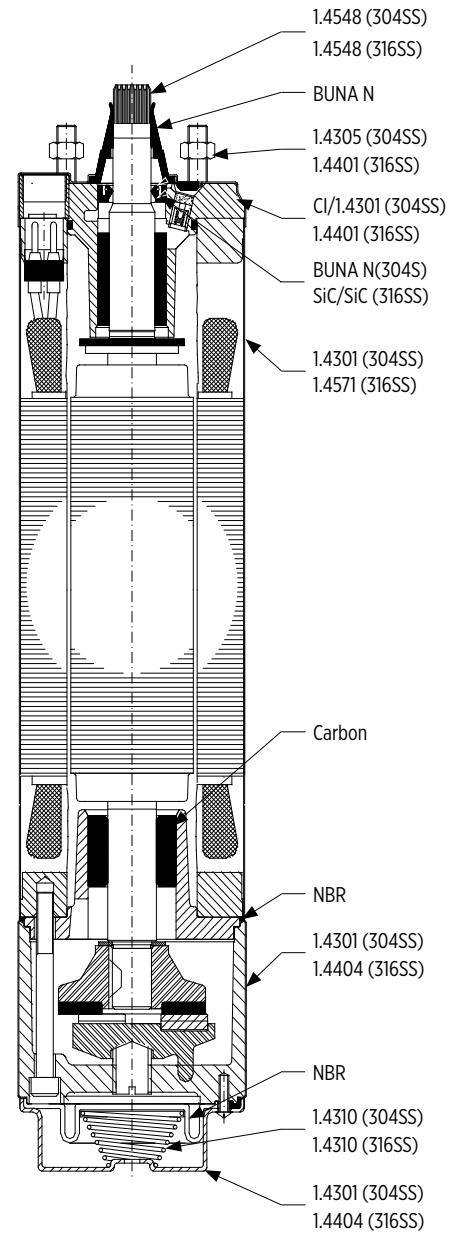
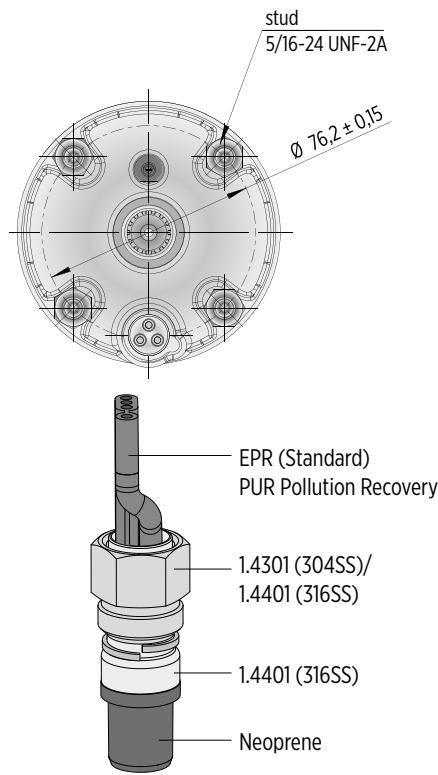
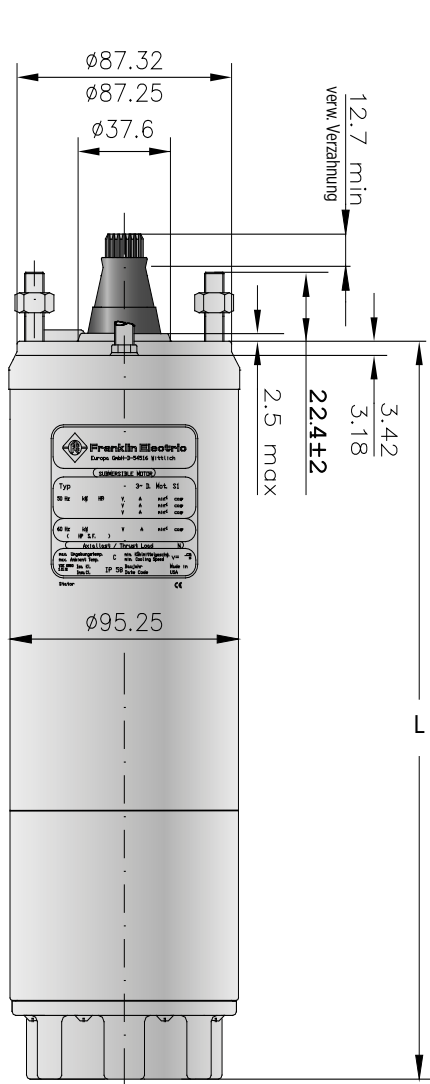

Tolerances according to NEMA MG 1-18.388

LENGTHS AND WEIGHTS - 3-WIRE DESIGN

P _N [kW]	P _{max} [kW]	304SS L [mm]	316SS L [mm]	304SS M [kg]	316SS M [kg]	motor with lead in single pack		
						[mm]	304SS [kg]	316SS [kg]
2,2	2,5	520,2	529,4	21,3	21,8	796 x 100 x 110	23,1	23,6
3,7	4,2	652,5	661,7	26,4	27,3	904 x 100 x 110	28,5	29,4

MOTOR LEADS

MOTOR LEADS 3-WIRE DESIGN

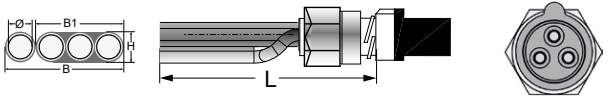
PSC / 3-wire / 3 Phase motor leads			
0.25 - 3.0 kW			
\emptyset [mm ²]	B [mm]	B1 [mm]	H [mm]
3X1,5 + 1G1,5	16,8	10,7	5,0
			
L [m]	Model numbers 304SS	Model numbers 316SS	
1,5	310 113 401	310 113 501	
2,5	310 113 402	310 113 502	
5	310 113 405	310 113 505	
10	310 113 410	310 113 510	
15	310 113 415	310 113 515	
20	310 113 420	310 113 520	
30	310 113 430	310 113 530	
40	310 113 440	310 113 540	
50	310 113 450	310 113 550	

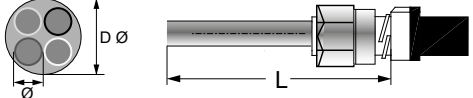
3-wire / 3-phase Pollution Recovery motor leads	
0.25 - 3.0 kW	
\emptyset [mm ²]	D \emptyset [mm]
1,5	9,8
	
L [m]	Model numbers 316SS
1,5	310 313 501
2,5	310 313 502
10	310 313 510
20	310 313 520
30	310 313 530
40	310 313 540
50	310 313 550

Cables are designed for submerged operation. For air operation, please consult Franklin Electric.

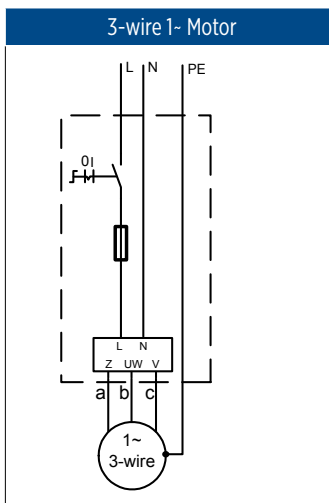

a = black | b = brown | c = grey | PE = yellow/green

MOTOR PART DESCRIPTION

MOTOR DESIGN 304SS 2,2 - 3,7 KW - 304SS

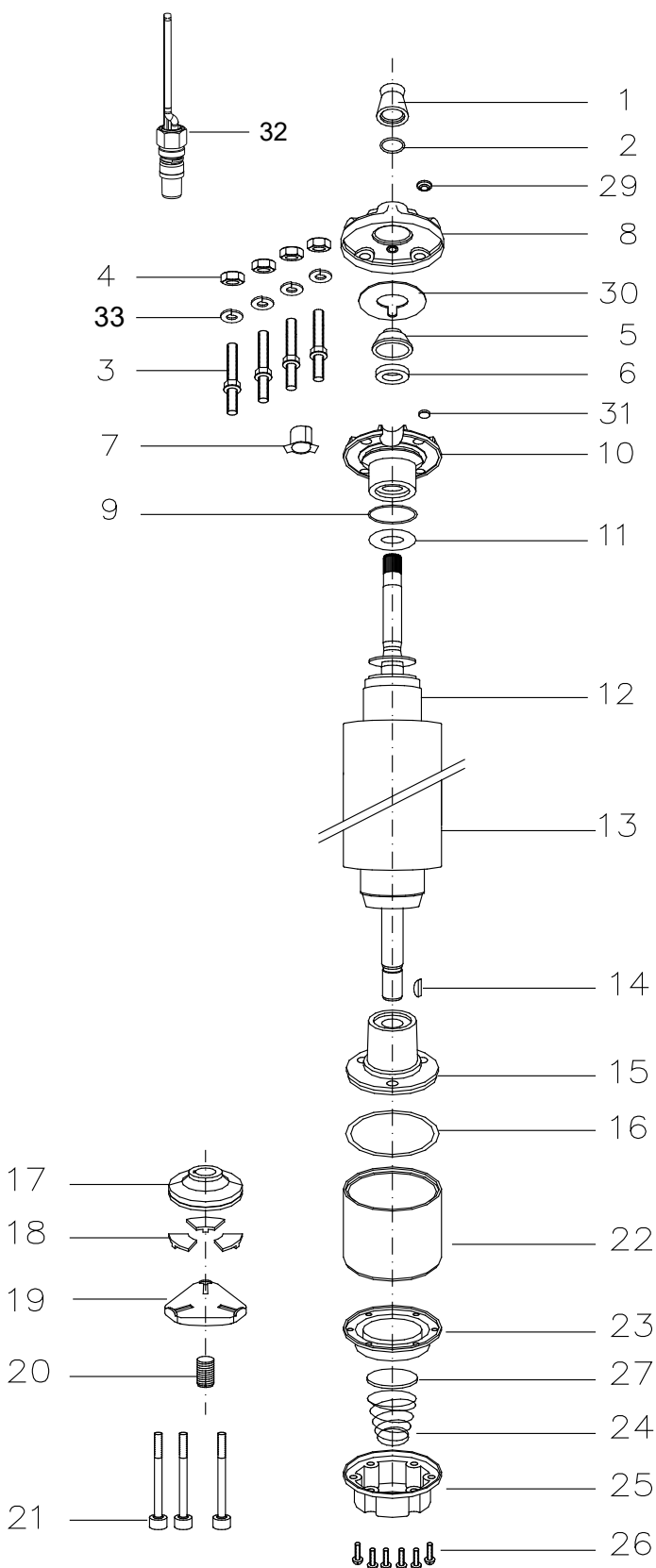

Pos.	Part Description	Qty.	Part No.
1	Protector, Spline	1	Kit B
2	Washer	1	Kit B
3	Stud	4	Kit C
4	Nut	4	Kit C
5	Seal cover	1	Kit D
6	Shaft Seal	1	Kit B+D
7	Connector boss	1	Kit D
8	Top Endbell, Cover	1	Kit D
9	O-Ring	1	Kit B+D
10	Top Endbell	1	Kit D
11	Upthrust washer 2,2 kW	1	308 268 104
	Upthrust washer 3,7 kW		308 317 901
12	Rotor	1	see page 30
13	Stator	1	see page 30
14	Woodruff key	1	275 250 104
15	Bottom Endbell	1	Kit
16	O-Ring	1	Kit B
17	Thrust disc	1	Kit A
18	Segment	1	Kit A
19	Leveling disc	1	155 660 101
20	Screw, adj.	1	151 048 102
21	Screw	3	Kit C
22	Thrust housing	1	177 378 901
23	Diaphragm	1	Kit B
24	Spring	1	151 449 101
25	Cover, Diaphragm	1	164 100 50
26	Screw	6	Kit C
27	Cup spring, Diaphragm	1	151 448 201
29	Sealing stopper	1	Kit B+D
30	Seal	1	Kit D
31	Filter	1	Kit B+D
32	Motor lead	1	see page 27
33	Lock washer	4	Kit C

PARTS DESCRIPTION

MOTOR DESIGN 316SS 2,2 - 3,7 kW - 316SS

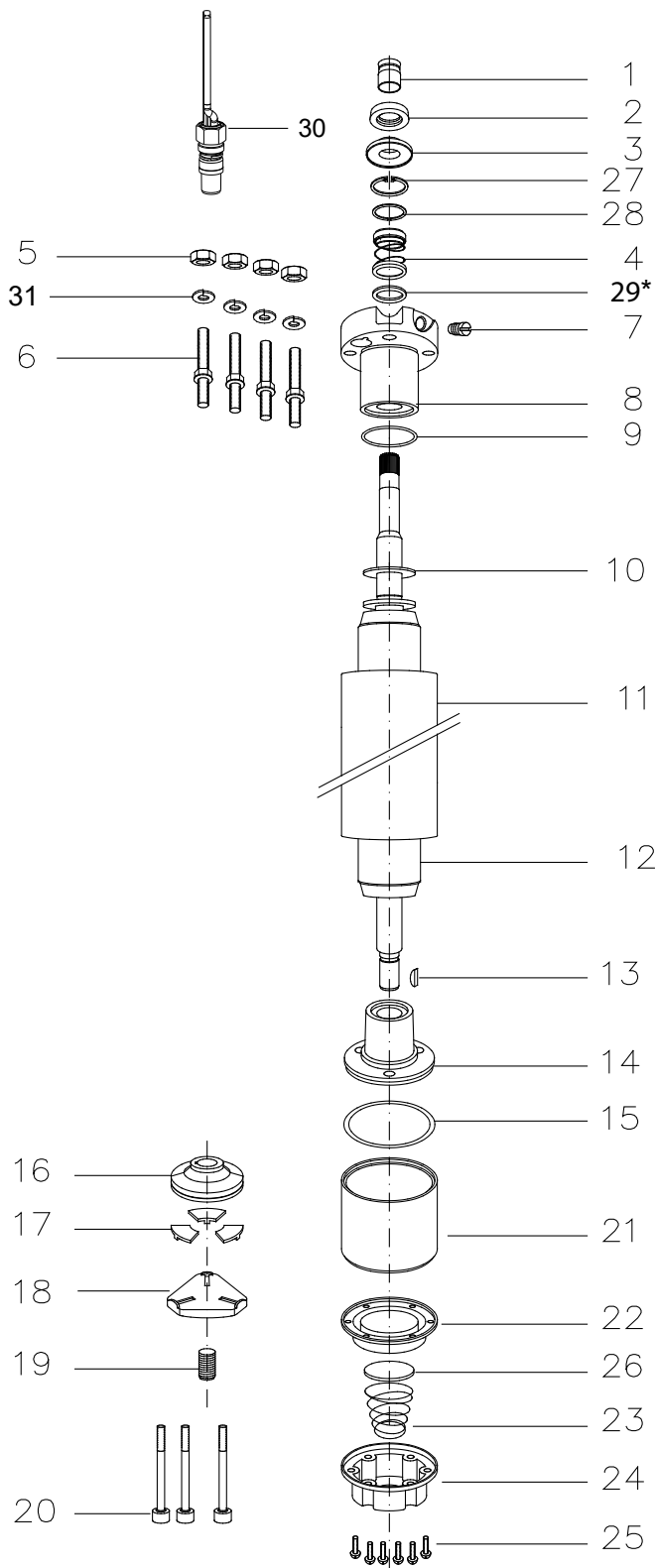

Pos.	Part Description	Qty.	Part No.
1	Protector, Spline	1	Kit C
2	Slinger	1	Kit C
3	Seal cover	1	Kit B + C
4	Shaft Seal	1	Kit B
5	Stud	4	Kit D
6	Nut	4	Kit D
7	Sealing Screw	1	308 279 903
8	Top Endbell	1	Kit
9	O-Ring	1	Kit B
10	Upthrust washer 2,2 kW	1	308 268 104
	Upthrust washer 3,7 kW		308 317 901
11	Stator	1	see page 30
12	Rotor	1	see page 30
13	Woodruff key	1	275 250 104
14	Bottom Endbell	1	Kit
15	O-Ring	1	Kit B
16	Thrust disc	1	Kit A
17	Segments	1	Kit A
18	Leveling disc	1	155 660 101
19	Screw, adj.	1	151 048 102
20	Screw	3	Kit D
21	Thrust housing	1	177 378 951
22	Diaphragm	1	Kit B
23	Spring	1	151 449 101
24	Cover, Diaphragm	1	364 100 50
25	Screw	6	Kit C
26	Cup spring, Diaphragm	1	151 448 201
27	Ring	1	Kit B
28	Retain Ring	1	Kit B
29*	Washer	1	308 747 201
30	Motor lead	1	see page 27
31	Lock washer	4	Kit C

* only for 2,2 - 3kW

MOTOR SPARE PARTS

SPARE PARTS KITS

P_N [kW]	2,2 / 3,7 kW		
2,2kW	End bell, upper 304SS	inkl. Pos. 5, 6, 7, 8, 9, 10, 29,30, 31	308 462 902
	End bell, upper 316SS	Pos. 8	177 390 955
3,7kW	End bell, upper 304SS	inkl. Pos. 5, 6, 7, 8, 9, 10, 29,30, 31	308 434 501
	End bell, upper 316SS	Pos. 8	177 390 955
Kit A	Thrust Bearing Kit 6500N	inkl. Pos.17. 18	308 700 301
Kit B	Seal Kit 304SS	inkl. Pos.: 1, 2, 6, 9, 16, 23,29, 31	308 900 351
	Seal Kit 316SS	inkl. Pos.: 4, 9, 15, 22, 27, 28	308 900 302
Kit B1	Seal Kit Pollution Recovery 304SS	inkl. Pos.: 1, 2, 6, 9, 16, 23,29, 31	308 900 401
Kit B2	Sand slinger Kit 316SS Motoren	inkl. Pos.: 1, 2, 3	308 825 201
Kit C	Screw Kit 304SS	inkl. Pos.: 3, 4, 21, 26, 33	308 658 351
	Screw Kit 316SS	inkl. Pos.: 5, 6, 20, 25, 31	308 658 301

SPARE PARTS - STATOR AND ROTOR 304SS - 3-WIRE DESIGN 50HZ

P_N [kW]	U_N [V]	Model nb. Stator 304SS / 316SS	Model nb. Rotor 304SS	Model nb. Rotor 316SS
2,2	220 / 230	305 491 181	178 126 903K	178 126 913K
3,7	220 / 230	305 491 182	178 133 903K	178 133 913K

SPARE PARTS - STATOR AND ROTOR 316SS- 3-WIRE DESIGN 50HZ

P_N [kW]	U_N [V]	Model nb. Stator 304SS / 316SS	Model nb. Rotor 304SS	Model nb. Rotor 316SS
2,2	220 / 230	305 491 541	178 126 903K	178 126 913K
3,7	220 / 230	305 491 542	178 133 903K	178 133 913K

SPARE PARTS - STATOR AND ROTOR 316SS- 3-WIRE DESIGN 60HZ

P_N [kW]	P_{max} [kW]	U_N [V]	Stator 60Hz	Rotor 60Hz
2,2	2,5	230	326 897 ***	178 126 903K
3,7	4,2	230	326 898 ***	178 135 903K

4" 3-PHASE HIGH THRUST MOTORS

OPTIONAL

STAINLESS STEEL
304

STAINLESS STEEL
316

FEATURES & BENEFITS

- NEMA mounting design
- Stainless steel splined shaft
- StatorShield™ - Franklin encapsulation system
- Factory filled with Franklin's FES93 motor fill solution
- Max. storage temperature -15°C - + 50°C
- Liquid lubricated radial bearings and High capacity Kingsbury type thrust bearing for 100 % maintenance free operation
- Field replaceable lead using Franklin's exclusive Water Bloc technology
- Pressure-equalizing diaphragm
- High efficiency electrical design for low operation costs
- Drinking water approvals
- Suitable for use in water with increased salinity (Brackish water version optional)



Pollution Recovery version:

- Fluorelastomere (Viton®) rubber parts
- Special Polyuretane (PUR) lead assemblies
- 304SS (316SS Stator) graded stainless steel as standard

SPECIFICATION

- Rating: 2,2 - 9,3kW
- Voltage: 3- - 230/400/500 V / 50 Hz, 230/380/460 V / 60 Hz
- Thrust load: 6,5 kN
- Nominal ambient temperature: 30 °C with 0.08 m/s cooling flow
- Voltage tolerance: -10 % / +6 % (50 Hz), ±10 % (60 Hz)
- Protection IP68 and insulation class B
- Frequency of starts: 20 starts/ hour (with min. 3 minutes resting time)
- Motors with factory installed leads (optional)
- Installation orientation: Vertical / horizontal (shaft end heightened)
- Rotation counter clock wise facing shaft end (Rotation CW upon request)

OPTIONS

- Built in lightning arrestors
- Various cable lengths
- Motors with factory-installed lead in single packing
- Motor complete in 316SS with SiC seal
- Special voltages



ISO 9001

All motors are manufactured in ISO 9001 certified plants and 100% tested



Hydrodynamic liquid lubricated radial bearings

100 % maintenance free operation

StatorSHIELD™ - Franklin encapsulation system

Franklin Electric encapsulated motors are equipped with hermetically-sealed windings. The Anti track stator resin mechanically supports the winding and provides fast heat dissipation.

Kingsbury type thrust bearing

High capacity 4 kN Kingsbury type thrust bearing for 100 % maintenance free operation

Pressure-equalizing diaphragm



4" SUPER STAINLESS MOTOR - 3-PHASE DESIGN

MOTOR MODEL NUMBERS 50 HZ - 3-PHASE DESIGN

P _N [kW]	U _N [V]	Digit 1 - 6		Digit 7 - 10					
				Standard 304SS		Standard 316SS		Pollution Recovery 304SS	Brackish water Motor
		DOL	YΔ (only 316SS)	Single pack, with lead*	40 motors packing unit	Single pack, with lead*	40 motors packing unit	Single pack, with lead*	Single pack, with lead*
2,2	220, 230	234 756	234 780	3421L	3421	3521L	3521	3422L	3424L
	380 - 415	234 726	234 770	3421L	3421	3521L	3521	3422L	3424L
	500	234 796	-	3421L	3421	3521L	3521	3422L	3424L
3,0	220, 230	234 766	234 781	3421L	3421	3521L	3521	3422L	3424L
	380 - 415	234 764	234 771	3421L	3421	3521L	3521	3422L	3424L
	500	234 768	-	3421L	3421	3521L	3521	3422L	3424L
3,7	220, 230	234 757	234 782	3421L	3421	3521L	3521	3422L	3424L
	380 - 415	234 727	234 772	3421L	3421	3521L	3521	3422L	3424L
	500	234 797	-	3421L	3421	3521L	3521	3422L	3424L
4,0	220, 230	234 767	234 783	3421L	3421	3521L	3521	3422L	3424L
	380 - 415	234 765	234 773	3421L	3421	3521L	3521	3422L	3424L
	500	234 769	-	3421L	3421	3521L	3521	3422L	3424L
5,5	220, 230	234 758	234 784	3421L	3421	3521L	3521	3422L	3424L
	380 - 415	234 728	234 778	3421L	3421	3521L	3521	3422L	3424L
	500	234 798	-	3421L	3421	3521L	3521	3422L	3424L
7,5	220, 230	-	-	3421L	3421	3521L	3521	3422L	3424L
	380 - 415	234 729	234 779	3421L	3421	3521L	3521	3422L	3424L
	500	234 799	-	3421L	3421	3521L	3521	3422L	3424L
9,3	380 - 415	234 788	-	3429L	-	3529L	-	-	-

* lead lengths motors: „L“ with 2.50 m pre-mounted cable

4" SUPER STAINLESS MOTOR - 3-PHASE DESIGN

MOTOR MODEL NUMBERS 60 HZ - 3-PHASE DESIGN

P _N [kW]	P _{N max.} [kW]	U _N [V]	Digit 1-6		Digit 7-10			
					Standard 304SS		Standard 316SS	
			DOL	YΔ (only 316SS)	40 motors packing unit	Single pack, with lead*	40 motors packing unit	Single pack, with lead*
2,2	2,5	230	234 716	234 780	3421	3421L	3521	3521L
		380	234 746	234 770	3421	3421L	3521	3521L
		460	234 726	-	3421E	3421EL	3521E	3521EL
3,0	3,4	230	234 776	234 781	3421	3421L	3521	3521L
		380	234 774	234 771	3421	3421L	3521	3521L
		460	234 764	-	3421E	3421EL	3521E	3521EL
3,7	4,2	230	234 717	234 782	3421	3421L	3521	3521L
		380	234 747	234 772	3421	3421L	3521	3521L
		460	234 727	-	3421E	3421EL	3521E	3521EL
4,0	4,7	230	234 777	234 783	3421	3421L	3521	3521L
		380	234 775	234 773	3421	3421L	3521	3521L
		460	234 765	-	3421E	3421EL	3521E	3521EL
5,5	6,4	230	234 718	234 784	3421	3421L	3521	3521L
		380	234 748	234 778	3421	3421L	3521	3521L
		460	234 728	-	3421E	3421EL	3521E	3521EL
7,5	8,6	230	234 719	-	3421	3421L	3521	3521L
		380	234 749	234 780	3421	3421L	3521	3521L
		460	234 729	-	3421E	3421EL	3521E	3521EL

* lead lengths motors: „L“ with 2.50 m pre-mounted cable

4" SUPER STAINLESS MOTOR - 3-PHASE DESIGN

MOTOR PERFORMANCE DATA 50 HZ - 3-PHASE DESIGN

P _N [kW]	Thrust F [N]	U _N [V]	n _N [min ⁻¹]	I _N [A]	I _A [A]	η (Eff.) [%] at % load			cos φ (Pf.) at % load			T _N [Nm]	T _A [Nm]
						50	75	100	50	75	100		
2,2	6500	220	2820	9,3	49,0	71	75	75	0,6	0,74	0,82	7,42	19,87
		230	2845	9,5	51,6	69	74	75	0,52	0,66	0,77	7,37	22
		380	2820	5,4	28,3	71	75	75	0,6	0,74	0,82	7,42	19,87
		400	2845	5,5	29,8	69	74	75	0,52	0,66	0,77	7,37	22
		415	2855	5,8	30,9	65	72	74	0,47	0,61	0,72	7,33	23,67
		500	2820	4,1	21,5	71	75	75	0,6	0,74	0,82	7,42	19,87
3	6500	220	2820	12,8	69,1	73	77	77	0,61	0,74	0,82	10,16	28,80
		230	2845	13,0	72,8	70	76	76	0,53	0,67	0,77	10,06	31,93
		380	2820	7,4	39,9	73	77	77	0,61	0,74	0,82	10,16	28,80
		400	2845	7,5	42,0	70	76	76	0,53	0,67	0,77	10,06	31,93
		415	2855	7,9	43,6	67	73	75	0,47	0,61	0,72	10,04	34,33
		500	2820	5,6	30,3	73	77	77	0,61	0,74	0,82	10,16	28,80
3,7	6500	220	2815	15,3	86,1	75	79	78	0,62	0,75	0,83	12,6	37,5
		230	2840	15,5	90,6	73	77	78	0,54	0,69	0,78	12,5	41,5
		380	2815	8,8	49,7	75	79	78	0,62	0,75	0,83	12,6	37,5
		400	2840	9,0	52,3	73	77	78	0,54	0,69	0,78	12,5	41,5
		415	2850	9,3	54,3	70	76	77	0,49	0,63	0,73	12,4	44,7
		500	2815	6,7	37,8	75	79	78	0,62	0,75	0,83	12,6	37,5
4	6500	220	2820	16,7	93,7	75	78	78	0,60	0,74	0,82	13,5	39,7
		230	2840	17,2	98,7	72	77	78	0,52	0,67	0,77	13,4	44,0
		380	2820	9,7	54,1	75	78	78	0,60	0,74	0,82	13,5	39,7
		400	2840	9,9	57,0	72	77	78	0,52	0,67	0,77	13,4	44,0
		415	2855	10,4	59,1	69	75	77	0,47	0,61	0,72	13,4	47,4
		500	2820	7,3	41,1	75	78	78	0,60	0,74	0,82	13,5	39,7
5,5	6500	220	2845	21,9	127,0	77	80	79	0,66	0,79	0,85	18,5	51,0
		230	2865	21,8	133,7	75	79	79	0,59	0,73	0,81	18,3	56,5
		380	2845	12,6	73,3	77	80	79	0,66	0,79	0,85	18,5	51,0
		400	2865	12,6	77,2	75	79	79	0,59	0,73	0,81	18,3	56,5
		415	2875	12,8	80,1	73	77	79	0,54	0,68	0,77	18,2	60,9
		500	2845	9,6	55,7	77	80	79	0,66	0,79	0,85	18,5	51,0
7,5	6500	380	2830	17,2	94,3	78	80	79	0,66	0,79	0,86	25,3	65,9
		400	2855	17,1	99,3	75	79	79	0,58	0,72	0,81	25,1	73,1
		415	2865	17,6	103,0	73	78	79	0,52	0,67	0,77	25,0	78,6
		500	2830	13,1	71,7	78	80	79	0,66	0,79	0,86	25,3	65,9
9,3	6500	380	2825	21,2	108,0	77	80	79	0,65	0,78	0,86	31,4	73,8
		400	2850	21,4	113,0	75	79	79	0,56	0,71	0,81	31,1	81,8
		415	2860	22,1	118,0	72	77	78	0,47	0,58	0,76	31,0	88,0

4" SUPER STAINLESS MOTOR - 3-PHASE DESIGN

MOTOR PERFORMANCE DATA 60 HZ - 3-PHASE DESIGN

P _N [kW]	P _{MAX} [kW]	Thrust F [N]	U _N [V]	n _N [min ⁻¹]	I _N [A]	I _A [A]	η (Eff.) [%] at % load			cos φ (Pf.) at % load			T _N [Nm]	T _A [Nm]
							50	75	100	50	75	100		
2,2	2,5	6500	230	3425	10,8	57,4	69	74	76	0,57	0,70	0,78	7,0	18,0
			380	3425	6,5	34,7	69	74	76	0,57	0,70	0,78	7,0	18,0
			460	3425	5,4	28,7	69	74	76	0,57	0,70	0,78	7,0	18,0
3	3,4	6500	230	3425	14,5	79,4	71	76	77	0,57	0,70	0,79	9,5	23,8
			380	3425	8,8	48,1	71	76	77	0,57	0,70	0,79	9,5	23,8
			460	3425	7,2	39,7	71	76	77	0,57	0,70	0,79	9,5	23,8
3,7	4,2	6500	230	3425	17,2	104	74	78	79	0,59	0,72	0,80	11,8	32,9
			380	3425	10,4	62,7	74	78	79	0,59	0,72	0,80	11,8	32,9
			460	3425	8,6	51,8	74	78	79	0,59	0,72	0,80	11,8	32,9
4	4,7	6500	230	3420	19,4	114	73	78	79	0,58	0,71	0,79	13,2	38,2
			380	3420	11,7	68,8	73	78	79	0,58	0,71	0,79	13,2	38,2
			460	3420	9,7	56,8	73	78	79	0,58	0,71	0,79	13,2	38,2
5,5	6,4	6500	230	3440	24,7	142	76	80	81	0,64	0,75	0,83	17,9	42,7
			380	3440	15,0	85,9	76	80	81	0,64	0,75	0,83	17,9	42,7
			460	3440	12,4	71,0	76	80	81	0,64	0,75	0,83	17,9	42,7
7,5	8,6	6500	380	3435	20,3	121	75	79	80	0,63	0,75	0,83	24,1	62,1
			460	3435	16,8	99,7	75	79	80	0,63	0,75	0,83	24,1	62,1

4" SUPER STAINLESS MOTOR - 3-PHASE DESIGN

WINDING RESISTANCE DATA 50 HZ - 3-PHASE DESIGN

P_N [kW]	U_N [V]	Stator-Ref.	U - V [Ohm]
2,2	220 - 230	326 780 902	2,5 - 3,0
	380 - 400 - 415	326 715 902	7,1 - 8,6
	500	326 792 902	11,9 - 14,5
3,0	220 - 230	326 781 902	1,5 - 1,9
	380 - 400 - 415	326 716 902	4,7 - 5,8
	500	326 793 902	8,4 - 10,2
3,7	220 - 230	326 784 902	1,2 - 1,5
	380 - 400 - 415	326 717 902	3,7 - 4,5
	500	326 796 902	6,5 - 7,9
4,0	220 - 230	326 785 902	1,1 - 1,3
	380 - 400 - 415	326 718 902	3,3 - 4,0
	500	326 797 902	5,8 - 7,1
5,5	220 - 230	326 786 902	0,9 - 1,1
	380 - 400 - 415	326 719 902	2,6 - 3,2
	500	326 798 902	4,6 - 5,7
7,5	380 - 400 - 415	326 720 902	1,9 - 2,3
	500	326 799 902	3,3 - 4,1
9,3	380 - 400 - 415	326 995 920	1,5 - 1,7

WINDING RESISTANCE DATA 60 HZ - 3-PHASE DESIGN

P_N [kW]	P_{MAX} [kW]	U_N [V]	Stator-Ref. #	U - V [Ohm]
2,2	2,5	230	326 833	1,8 - 2,2
		380	326 843	4,9 - 6,0
		460	326 715	7,1 - 8,6
3	3,4	230	326 834	1,2 - 1,4
		380	326 844	3,2 - 4,0
		460	326 716	6,5 - 8,0
3,7	4,2	230	326 835	0,9 - 1,1
		380	326 845	2,6 - 3,1
		460	326 717	3,7 - 4,5
4	4,7	230	326 836	0,8 - 1,0
		380	326 846	2,4 - 2,9
		460	326 718	3,3 - 4,0
5,5	6,4	230	326 837	0,7 - 0,8
		380	326 847	1,8 - 2,2
		460	326 719	2,6 - 3,2
7,5	8,6	380	326 848	1,3 - 1,6
		460	326 720	1,9 - 2,3

MOTOR DESIGN AND DIMENSIONS

MOTOR DESIGN HIGH THRUST 6500N 2,2 - 7,5 KW

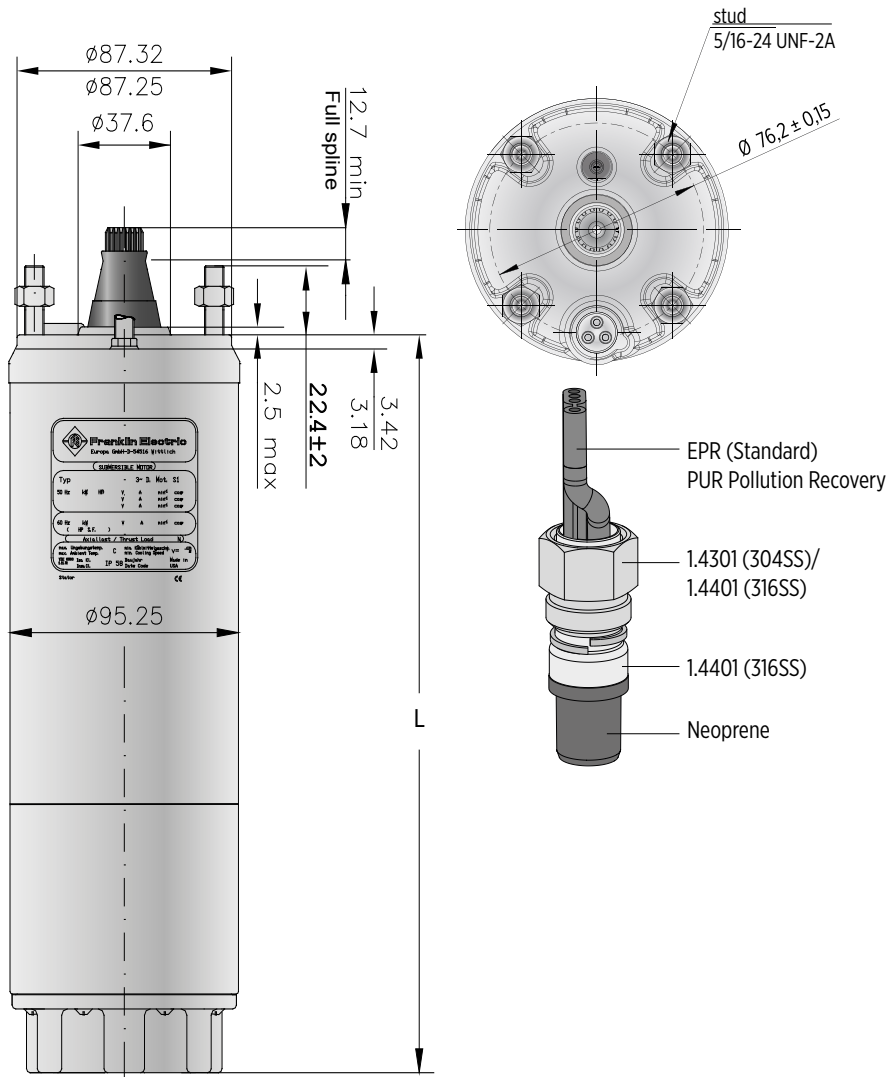

Tolerances according to NEMA MG 1-18.388

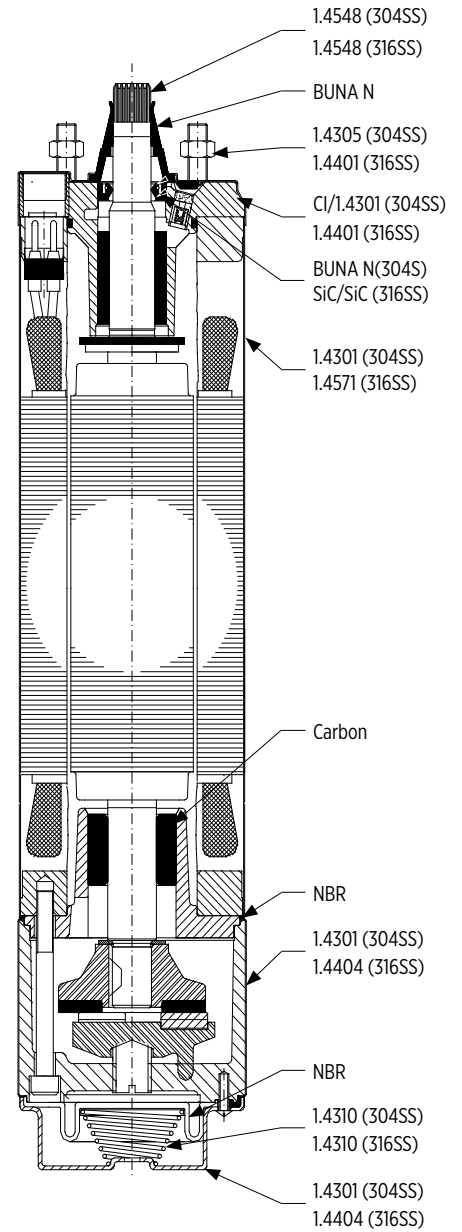

LENGTHS AND WEIGHTS - 3-PHASE DESIGN

P_N		304SS	316SS	304SS	316SS	motor with lead in single pack	
[kW]	[HP]	L [mm]	L [mm]	M [kg]	M [kg]	[mm]	304SS [kg]
2,2	3	422,2	431,4	15,0	15,5	796 x 100 x 110	16,8
3,0	4	477,2	486,4	17,0	17,5	796 x 100 x 110	18,9
3,7	5	520,2	529,4	19,1	19,6	796 x 100 x 110	20,9
4,0	5,5	543,2	552,4	20,0	20,5	796 x 100 x 110	21,8
5,5	7,5	652,5	661,7	26,6	27,1	904 x 100 x 110	28,7
7,5	10	730,5	739,7	30,6	31,1	904 x 100 x 110	32,7

MOTOR DESIGN AND DIMENSION

MOTOR DESIGN HIGH THRUST 6500N 9,3 KW

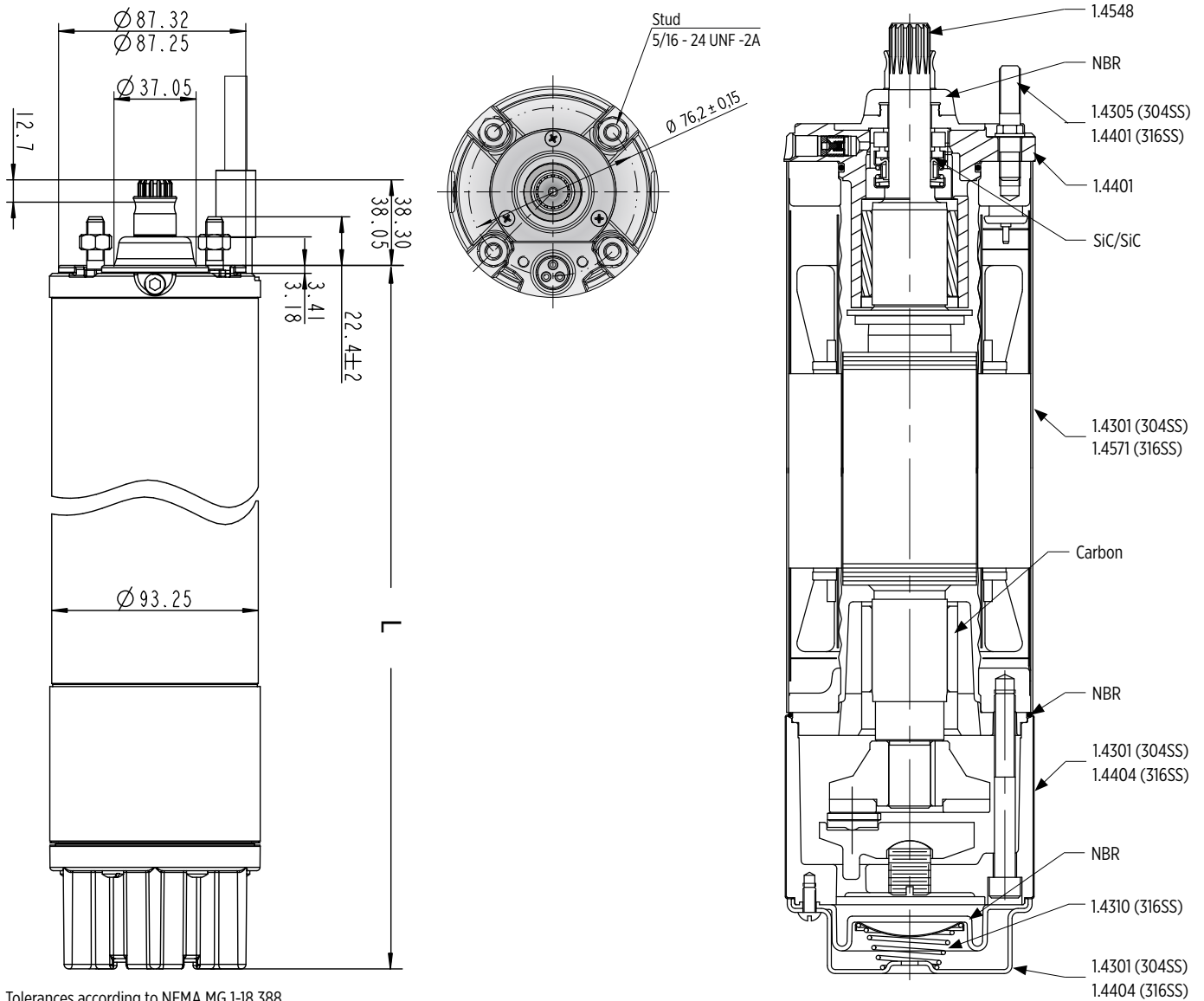

Tolerances according to NEMA MG 1-18.388

LENGTHS AND WEIGHTS - 3-PHASE DESIGN

P _N [kW]	L [mm]	M [kg]	Motor with Lead in single pack	
			[mm]	[kg]
9,3	855,1	37,9	904 x 100 x 110	41,3

MOTOR LEADS

MOTOR LEADS 3~ DESIGN DOL

3 Phase motor leads			
2,2 - 7,5 kW			
Ø [mm ²]	B [mm]	B1 [mm]	H [mm]
3X1,5 + 1G1,5	16,8	10,7	5,0
L [m]	Model numbers 304SS	Model numbers 316SS	
1,5	310 113 401	310 113 501	
2,5	310 113 402	310 113 502	
5	310 113 405	310 113 505	
10	310 113 410	310 113 510	
15	310 113 415	310 113 515	
20	310 113 420	310 113 520	
30	310 113 430	310 113 530	
40	310 113 440	310 113 540	
50	310 113 450	310 113 550	

3 Phase motor leads			
9,3 kW			
Ø [mm ²]	B [mm]	B1 [mm]	H [mm]
3X1,5 + 1G1,5	16,8	10,7	5,0
L [m]	Model numbers		
2,5	310 116 502K		
5	310 116 505K		
10	310 116 510K		
20	310 116 520K		
30	310 116 530K		

3-phase Pollution Recovery motor leads	
0.25 - 3.0 kW	
Ø [mm ²]	D Ø [mm]
1,5	9,8
L [m]	Model numbers 316SS
1,5	310 313 501
2,5	310 313 502
10	310 113 510
20	310 313 520
30	310 313 530
40	310 313 540
50	310 313 550

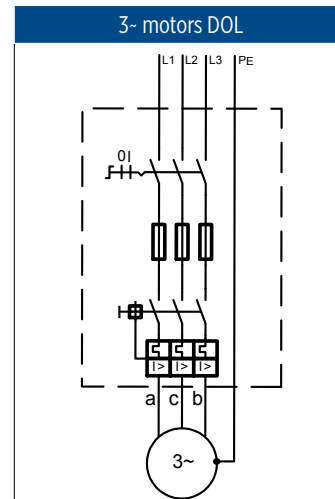

a = black | b = brown | c = grey | PE = yellow/green

Cables are designed for submerged operation. For air operation, please consult Franklin Electric.

MOTOR PART DESCRIPTION

MOTOR DESIGN 304SS 2,2 - 7,5 KW

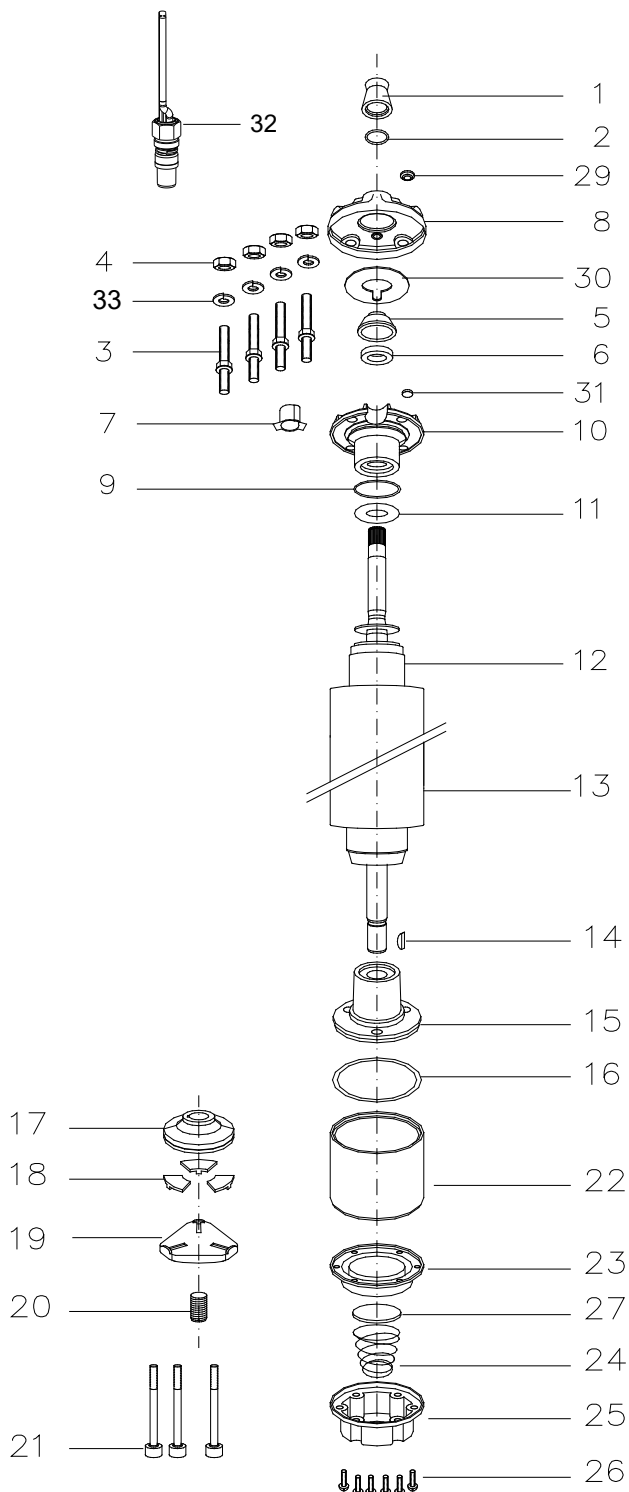

Pos.	Part Description	Qty.	Part No.
1	Protector, Spline	1	Kit B
2	Washer	1	Kit B
3	Stud	4	Kit C
4	Nut	4	Kit C
5	Seal cover	1	Kit D
6	Shaft Seal	1	Kit B+D
7	Connector boss	1	Kit D
8	Top Endbell, Cover	1	Kit D
9	O-Ring	1	Kit B+D
10	Top Endbell	1	Kit D
11	Upthrust washer 2,2 - 4,0	1	308 268 104
	Upthrust washer 5,5 - 7,5	1	308 317 901
12	Rotor	1	see page 52/53
13	Stator	1	see page 52/53
14	Woodruff key	1	275 250 104
15	Bottom Endbell	1	Kit
16	O-Ring	1	Kit B
17	Thrust disc	1	Kit A
18	Segment	1	Kit A
19	Leveling disc	1	155 660 101
20	Screw, adj.	1	151 048 102
21	Screw	3	Kit C
22	Thrust housing	1	177 378 901
23	Diaphragm	1	Kit B
24	Spring	1	151 449 101
25	Cup spring, Diaphragm	1	164 100 50
26	Screw	6	Kit C
27	Cup spring, Diaphragm	1	151 448 201
28	Sealing stopper	1	Kit B+D
29	Seal	1	Kit D
30	Filter	1	Kit B+D
31	Motor lead	1	see page 50
32	Lock washer	4	Kit C

MOTOR SPARE PARTS

SPARE PARTS KITS

P_N [kW]	2,2 - 7,5 kW		
2,2- 4,0kW	End bell, upper	incl. Pos.: 5, 6, 7, 8, 9, 10, 29, 30, 31	308 233 509
	End bell, lower	incl. Pos.: 15	177 379 921
5,5 - 7,5kW	End bell, upper	incl. Pos.: 5, 6, 7, 8, 9, 10, 29, 30, 31	308 434 501
	End bell, lower	incl. Pos.: 15	177 379 901
Kit A	Thrust bearing Kit 6500N	incl. Pos. 17, 18	308 700 301
Kit B	Seal Kit 304SS	incl. Pos.: 1, 2, 6, 9, 16, 23, 29, 31	308 900 351
Kit B1	Seal Kit Pollution Recovery 304SS	incl. Pos.: 1, 2, 6, 9, 16, 23, 29, 31	308 900 401
Kit C	Screw Kit 304SS	incl. Pos.: 3, 4, 21, 26, 33	308 658 351

SPARE PARTS - STATOR AND ROTOR 304SS - 3-PHASE DESIGN 50HZ

P_N [kW]	U_N [V]	Motor Model No.	Stator Model No.	Rotor
2,2	220, 230	234 756 3421/3422	305 491 361	178 163 903K
	380, 400, 415	234 726 3421/3422	305 491 381	
	500	234 796 3421/3422	305 491 401	
3,0	220, 230	234 766 3421/3422	305 491 362	178 125 903K
	380, 400, 415	234 764 3421/3422	305 491 382	
	500	234 768 3421/3422	305 491 402	
3,7	220, 230	234 757 3421/3422	305 491 363	178 126 903K
	380, 400, 415	234 727 3421/3422	305 491 383	
	500	234 797 3421/3422	305 491 403	
4,0	220, 230	234 767 3421/3422	305 491 364	178 127 903K
	380, 400, 415	234 765 3421/3422	305 491 384	
	500	234 769 3421/3422	305 491 404	
5,5	220, 230	234 758 3421/3422	305 491 365	178 133 903K
	380, 400, 415	234 728 3421/3422	305 491 385	
	500	234 798 3421/3422	305 491 405	
7,5	380, 400, 415	234 729 3421/3422	305 491 386	178 134 903K
	500	234 799 3421/3422	305 491 406	

SPARE PARTS - STATOR AND ROTOR 304SS - 3-PHASE DESIGN 60HZ

P_N [kW]	P_{MAX} [kW]	U_N [V]	Stator*	Rotor
2,2	2,5	230		178 163 903K
		380		
		460		
3,0	3,4	230		178 125 903K
		380		
		460		
3,7	4,2	230		178 126 903K
		380		
		460		
4,0	4,7	230		178 127 903K
		380		
		460		
5,5	6,4	230		178 133 903K
		380		
		460		
7,5	8,6	380		178 134 903K
		460		

* 60 Hz Stators on request

MOTOR PART DESCRIPTION

MOTOR DESIGN 316SS 2,2 - 7,5 KW

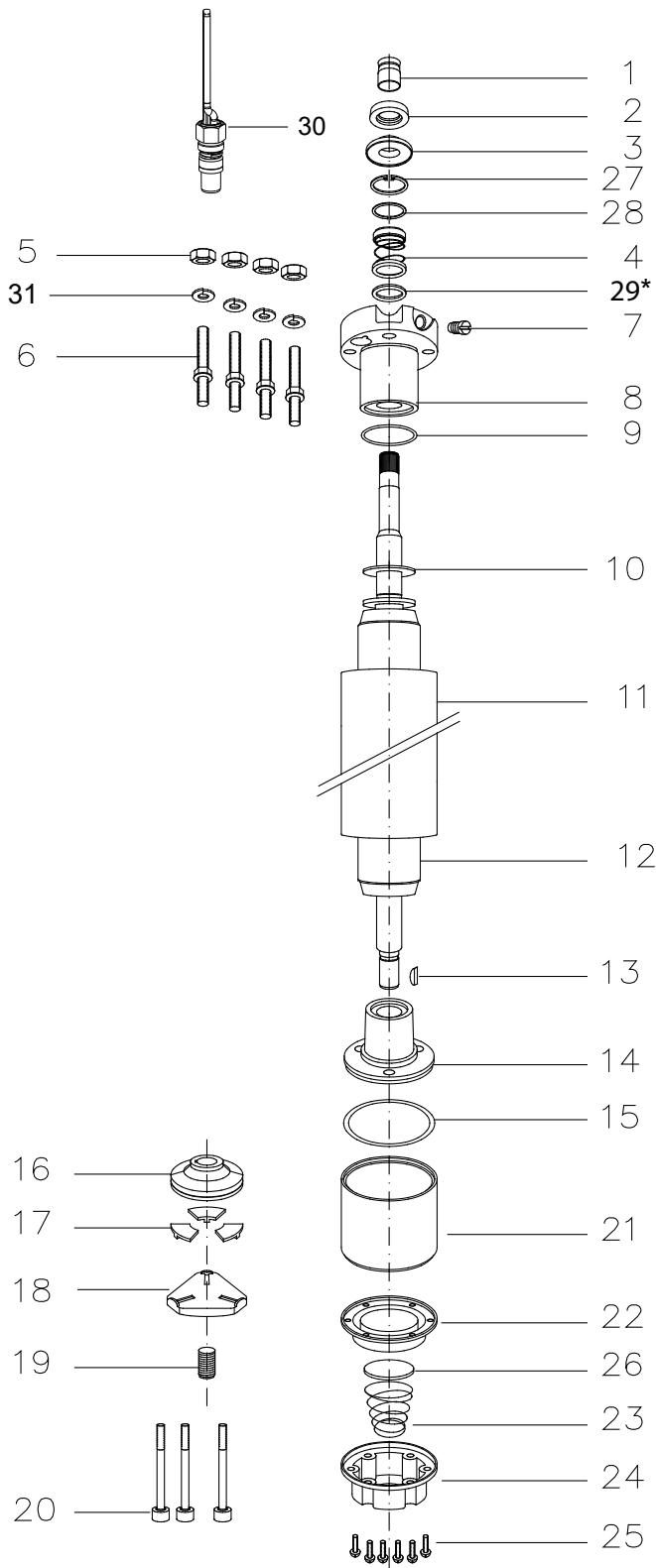

Pos.	Part Description	Qty.	Part No.
1	Protector, Spline	1	Kit C
2	Slinger	1	Kit C
3	Seal cover	1	Kit B + C
4	Shaft Seal	1	Kit B
5	Nut	4	Kit D
6	Stud	4	Kit D
7	Sealing Screw	1	308 279 903
8	Top Endbell	1	Kit
9	O-Ring	1	Kit B
10	Upthrust washer	1	Kit
11	Stator	1	see page 55/56
12	Rotor	1	see page 55/56
13	Woodruff key	1	275 250 104
14	Bottom Endbell	1	Kit
15	O-Ring	1	Kit B
16	Thrust disc	1	Kit A
17	Segments	1	Kit A
18	Leveling disc	1	155 660 101
19	Screw, adj.	1	151 048 102
20	Screw	3	Kit D
21	Thrust housing	1	177 378 951
22	Diaphragm	1	Kit B
23	Spring	1	151 449 101
24	Cover, Diaphragm	1	364 100 50
25	Screw	6	Kit D
26	Cup spring, Diaphragm	1	151 448 201
27	Ring	1	Kit B
28	Retain Ring	1	Kit B
29*	Washer	1	308 747 201
30	Motor lead	1	see page 50
31	Lock washer	4	Kit D

* only for 2,2 - 3kW

MOTOR SPARE PARTS

SPARE PARTS KITS

P_N [kW]	2,2 - 7,5 kW		
2,2 - 4,0kW	End bell, upper 316SS - DOL	incl. Pos. 8	177 390 955
	End bell, upper 316SS - YD		177 390 956
5,5 - 7,5kW	End bell, upper 316SS - DOL	incl. Pos. 8	177 390 951
	End bell, upper 316SS - YD		177 390 953
Kit A	Thrust bearing Kit 6500N	incl. Pos. 16, 17	308 700 301
Kit B	Seal Kit 304SS	incl. Pos.: 4, 9, 15, 22	308 900 302
Kit B1	Seal Kit Pollution Recovery 304SS	incl. Pos.: 1, 2, 3, 4, 9, 15, 22, 27, 28	308 900 402
Kit C	Sand slinger Kit 316SS Motors	incl. Pos.: 1, 2, 3	308 825 201
Kit D	Screw Kit 316SS	incl. Pos.: 5, 6, 20, 25, 31	308 658 301

SPARE PARTS - STATOR AND ROTOR 316SS - 3-PHASE DESIGN 50HZ

P_N [kW]	U_N [V]	Motor Model No.	Stator Model No.	Rotor
2,2	220, 230	234 756 3521/3522	305 491 641	178 163 913K
	380, 400, 415	234 726 3521/3522	305 491 661	
	500	234 796 3521/3522	305 491 681	
3,0	220, 230	234 766 3521/3522	305 491 642	178 125 913K
	380, 400, 415	234 764 3521/3522	305 491 662	
	500	234 768 3521/3522	305 491 682	
3,7	220, 230	234 757 3521/3522	305 491 643	178 126 913K
	380, 400, 415	234 727 3521/3522	305 491 663	
	500	234 797 3521/3522	305 491 683	
4,0	220, 230	234 767 3521/3522	305 491 644	178 127 913K
	380, 400, 415	234 765 3521/3522	305 491 664	
	500	234 769 3521/3522	305 491 684	
5,5	220, 230	234 758 3521/3522	305 491 645	178 133 913K
	380, 400, 415	234 728 3521/3522	305 491 665	
	500	234 798 3521/3522	305 491 685	
7,5	380, 400, 415	234 729 3521/3522	305 491 666	178 134 913K
	500	234 799 3521/3522	305 491 686	

SPARE PARTS - STATOR AND ROTOR 316SS - 3-PHASE DESIGN 60HZ

P_N [kW]	P_{MAX} [kW]	U_N [V]	Stator*	Rotor
2,2	2,5	230		178 163 913K
		380		
		460		
3,0	3,4	230		178 125 913K
		380		
		460		
3,7	4,2	230		178 126 913K
		380		
		460		
4,0	4,7	230		178 127 913K
		380		
		460		
5,5	6,4	230		178 133 913K
		380		
		460		
7,5	8,6	380		178 134 913K
		460		

* 60 Hz Stators on request

MOTOR PART DESCRIPTION

MOTOR DESIGN 9,3 KW

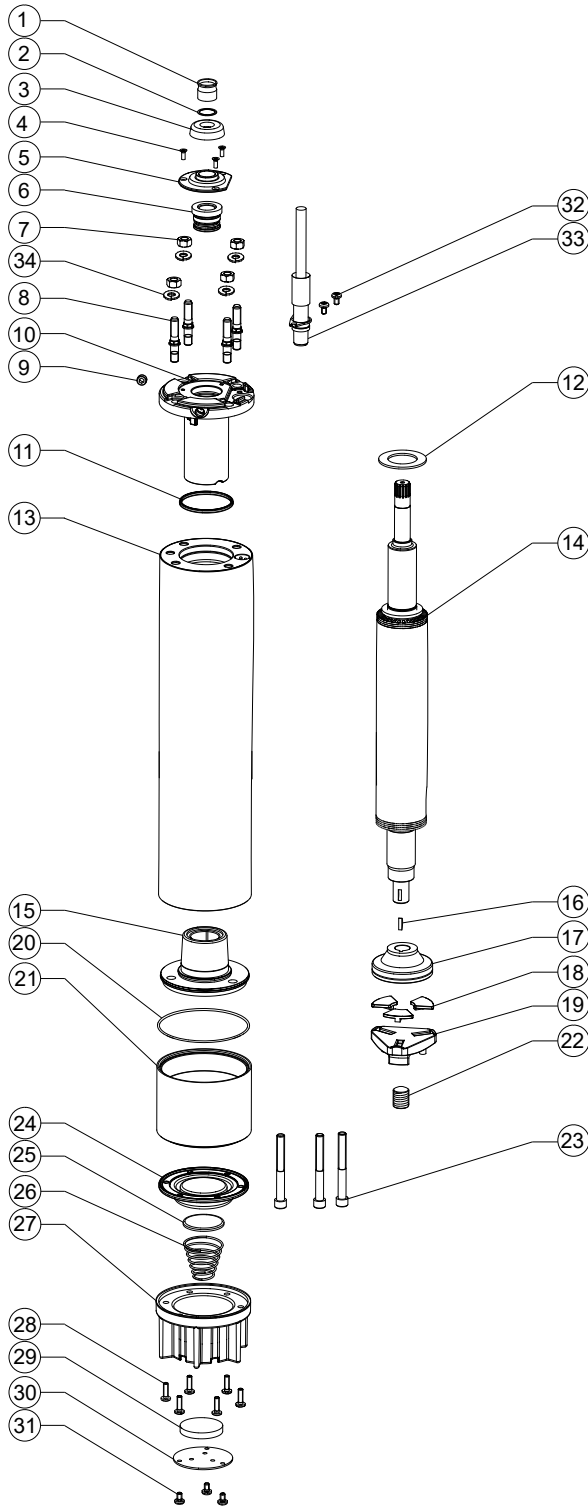

Pos.	Description	Qty.	Part Nb.
1	Protector, Spline	1	Kit B
2	Washer	1	275 542 102
3	Slinger	1	Kit B
4	Screw, Seal cover	3	Kit C
5	Seal cover	1	156 275 102
6	Shaft Seal	1	Kit B
7	Nut	4	Kit C
8	Stud	4	Kit C
9	Plug screw	1	282 230 101
10	Top Endbell	1	177 553 901
11	O-Ring	1	Kit B
12	Upthrust washer	1	308 317 901
13	Stator	1	see page 58
14	Rotor	1	see page 58
15	Bottom Endbell	1	177 379 901
16	Woodruff key	1	275 250 104
17	Thrust disc	1	Kit A
18	Segments	3	Kit A
19	Leveling disc	1	155 660 101
20	O- Ring	1	Kit B
21	Thrust housing	1	177 378 901
22	Screw, adj.	1	151 048 102
23	Screw	3	Kit C
24	Diaphragm	1	Kit B
25	Cup spring, Diaphragm	1	151 448 201
26	Spring	1	151 449 101
27	Diaphragm housing	1	177 965 101
28	Screw	6	Kit C
29	Filter	1	156 276 101
30	Cover, Diaphragm	1	156 278 101
31	Screw	3	Kit C
32	Screw	2	Kit C
33	Motor cable, 2,5m	1	see page 50
34	Lock washer	4	Kit C

MOTOR SPARE PARTS

SPARE PARTS KITS

P_N [kW]	9,3 kW		
Kit A	Thrust bearing Kit 6500N	incl. Pos.17. 18	308 700 301
Kit B	Seal Kit 304SS / 316SS	incl. Pos.: 1, 3, 6, 11, 20, 24	308 900 501
Kit C	Screw Kit 304SS / 316SS	incl. Pos.: 4; 7; 8; 23; 28; 31; 32, 34	308 658 501

SPARE PARTS - STATOR AND ROTOR - 3-PHASE DESIGN 50HZ

P_N [kW]	U_N [V]	Modellnr. Stator 304SS / 316SS	Modellnr. Rotor 304SS/316SS
9,3	380 - 415	326 995 920K	178 139 915K

* 60 Hz Stators on request